



eCATALOG
SOLUTIONS

THE ELECTRONIC PRODUCT CATALOG

UNIQUE SOLUTIONS FOR MARKETING, SALES AND ENGINEERING



Current use cases - VIDEO

eCATALOG
SOLUTIONS

THE ELECTRONIC
PRODUCT CATALOG



Company & Logo



Founded 1992
100 % privately owned
Process chains
(CADENAS Spanish for chains)

About me



Jürgen
Heimbach



Employees



~ 250 worldwide





CADENAS Products

Link between manufacturers of components and the industry

eCATALOG SOLUTIONS
THE ELECTRONIC PRODUCT CATALOG



KOMPONENTENHERSTELLER



INDUSTRIE

> 600 catalog manufacturers from all industries cooperate with CADENAS

75 % of the **TOP 25** most popular manufacturers already work with CADENAS

> 10.000 companies with
> 450.000 users utilize Parts Management
154 of them are among the **TOP 1000** global players from Germany
Moreover CADENAS has access to **7,000,000** potential web downloaders

Purchase and engineering departments use CADENAS very frequently for **product design** as well as **manufacturing equipment and tooling** in **ET/NT and KT!**





How does creativity work in engineering?

BASIC ELEMENTS OF CREATIVE ENGINEERING

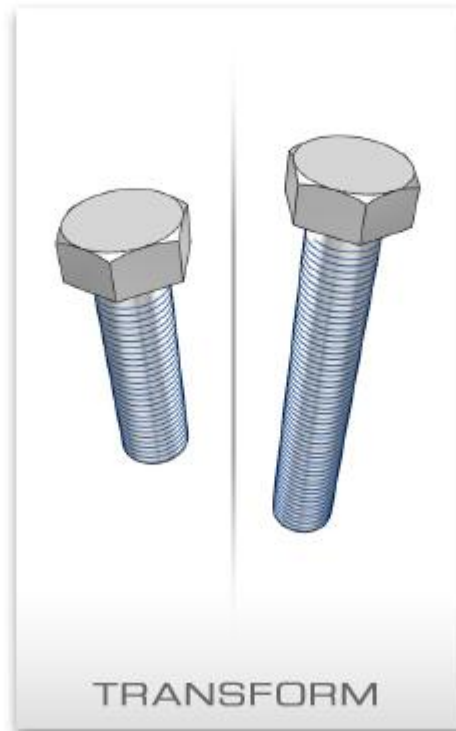
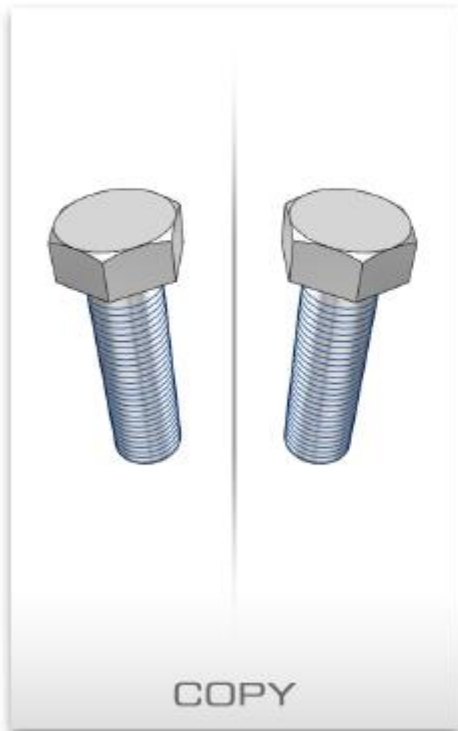



Interactive dictionary

Imparting knowledge faster

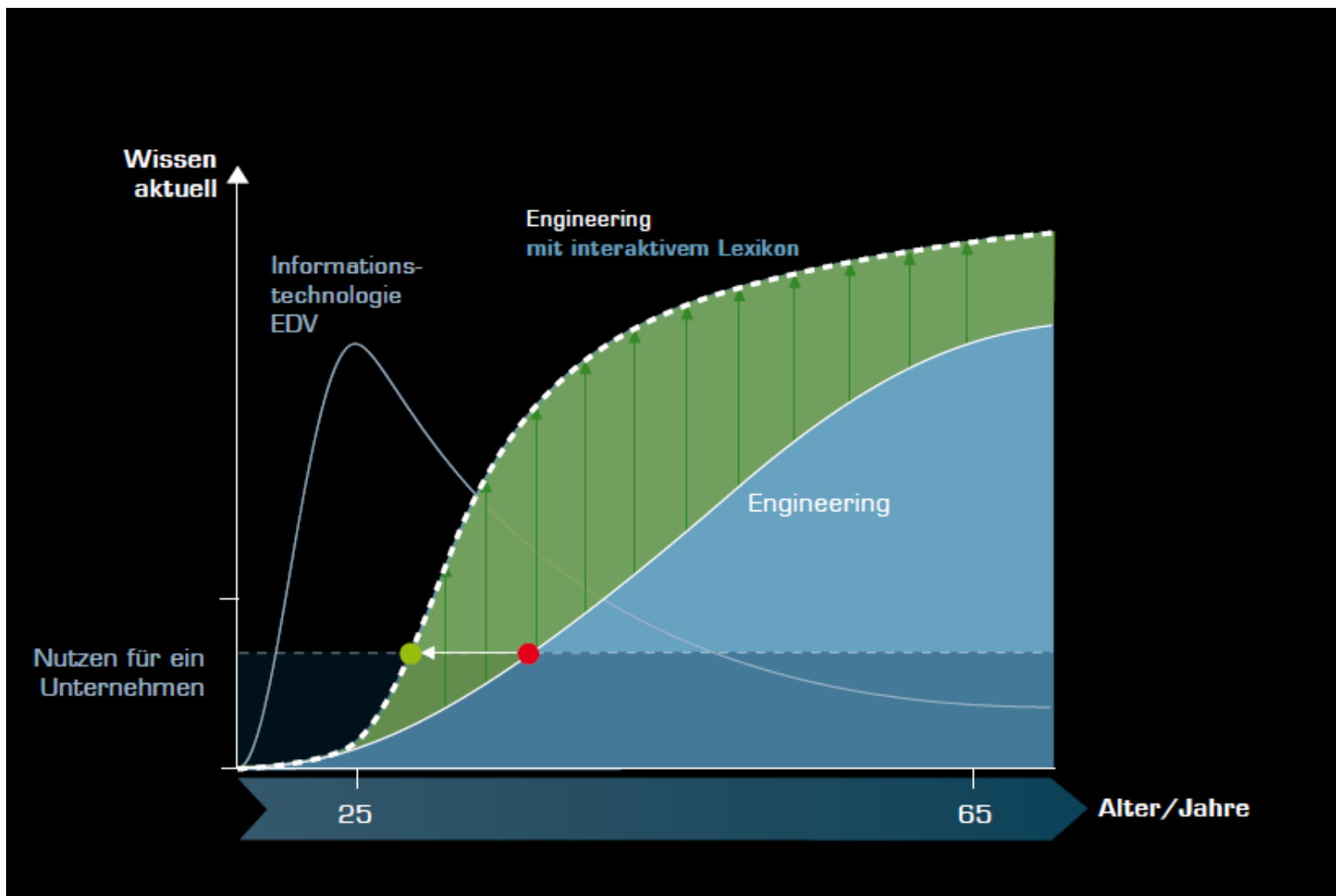



Interactive dictionary

Imparting knowledge faster

eCATALOG
SOLUTIONS

THE ELECTRONIC
PRODUCT CATALOG

PARTdataManager 9.00 BETA - PARTsolutions by CADENAS - D:\psol_9_0\software\...\data\23d-libs\vesto\parts\d\dnc\dnc.prj - [NB = 163414 DNC-63-3-PPV---(asm_0), LOD = HI_AUTO]

Fichier Export Affichage Tableau Configurateur Outils Fenêtre ?

Explorateur Projet 3D Vue 2D Boulonnage Recherche textuelle Recherche 2D Recherche 3D Anwennderportal

Video of functionality

Samples of usage

Online connection

Special thread Yes

Hollow piston Yes

Delivery ex-stock

Standard cylinder As per ISO 15552, with profile with adjustable cushioning at both end positions. → more

27.04.2000 #182 Admin



Help the customer with example cases and experience

Auswahl CAD MODELLE

Alle Kataloge > AMF - ANDREAS MAIER GMBH & CO KG > Vakuumspanntechnik > AMF 7800B - Vakuumspannplatte

Navigation Allgemein

Zurück Startseite QA Siegel Sprache

Klassifikationen

Alle Kataloge Zertifizierte Kataloge Alle Kategorien Alle Länder Alphabetisch

Weiterempfehlen

Facebook

Aktionen

Schritt 1: Als Juergen Heimbach posten Kommentieren

Schritt 2: CADENAS Person

Schritt 3: AMF Vakuumspanntechnik
Die AMF-Vakuumspanntechnik im Einsatz bei der Bearbeitung von Kunststoff. Durch die integrierte Venturidüse wird die Vakuumspannplatte kostengünstig mit der vorhandenen Druckluftleitung betrieben. Ein Betrieb mittels einer Vakuumpumpe ist ebenfalls möglich.

Optional:

CAD MODELLE

Nach geometrie

2 Spannplatte

3

4

Montage 1

Montage 2

Suche nach CAD MODELLEN

Volltext Variablen Geometrisch 3D Skizze 2D

Katalog

Alle Kataloge

Suchkriterien

Suchtext: Suchen

Vorsicht CAD MODELL

Vorschau Animation Maßbild 3D-PDF

Dies ist eine vorgenerierte Standardansicht, die sich von Ihrer Auswahl unterscheiden kann.



Use cases

Our motivation: The biggest engineering encyclopedia in the world

APP



PARTCOMMUNITY/WEB

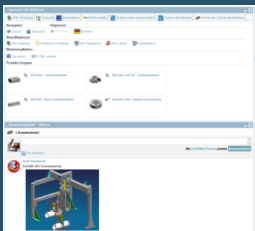

PARTSOLUTIONS

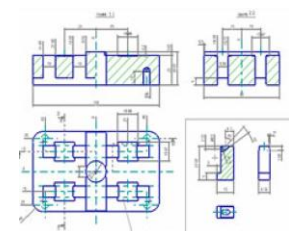
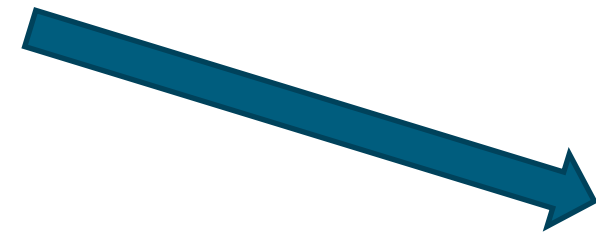
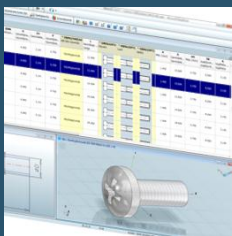

Pictures of 2D DRAWINGS

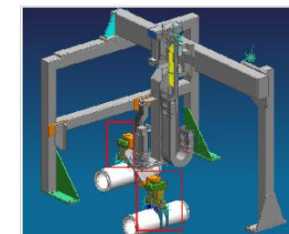

Pictures of 3D CAD MODELS and DATA

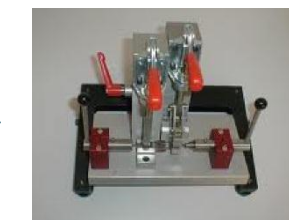

REALISTIC PHOTOS and VIDEOS



Use cases

Our motivation: The biggest engineering encyclopedia in the world

Define users

WHICH MANUFACTURER WAS USED?

FESTO, SKF, ...

WHICH CAD WAS USED?

CATIA, NX, PRO/E, ...

WHO DESIGNED?

DESIGN OFFICE MEIER Hans Huber

WHAT KIND OF MACHINE/DESIGN?

FIXTURE, WELDING SYSTEM, SPECIAL MACHINE, ...

WHICH COMPONENT WAS USED?

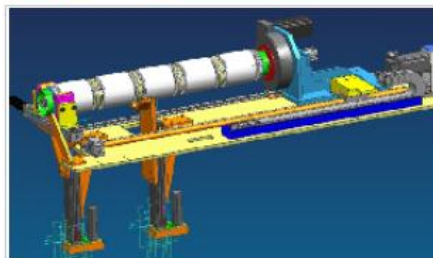
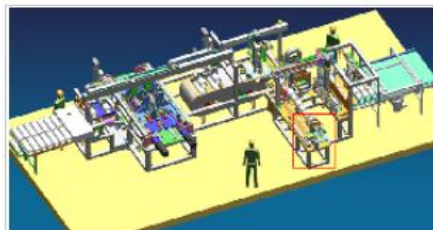

LANGUAGE?

GERMAN; ENGLISH; JAPANESE, ...

WHICH FUNCTIONS ARE COVERED?

BENDING, WELDING, MEASURING, GRIPPING, ...





Use cases

Result is an ENGINEERING
knowledge network

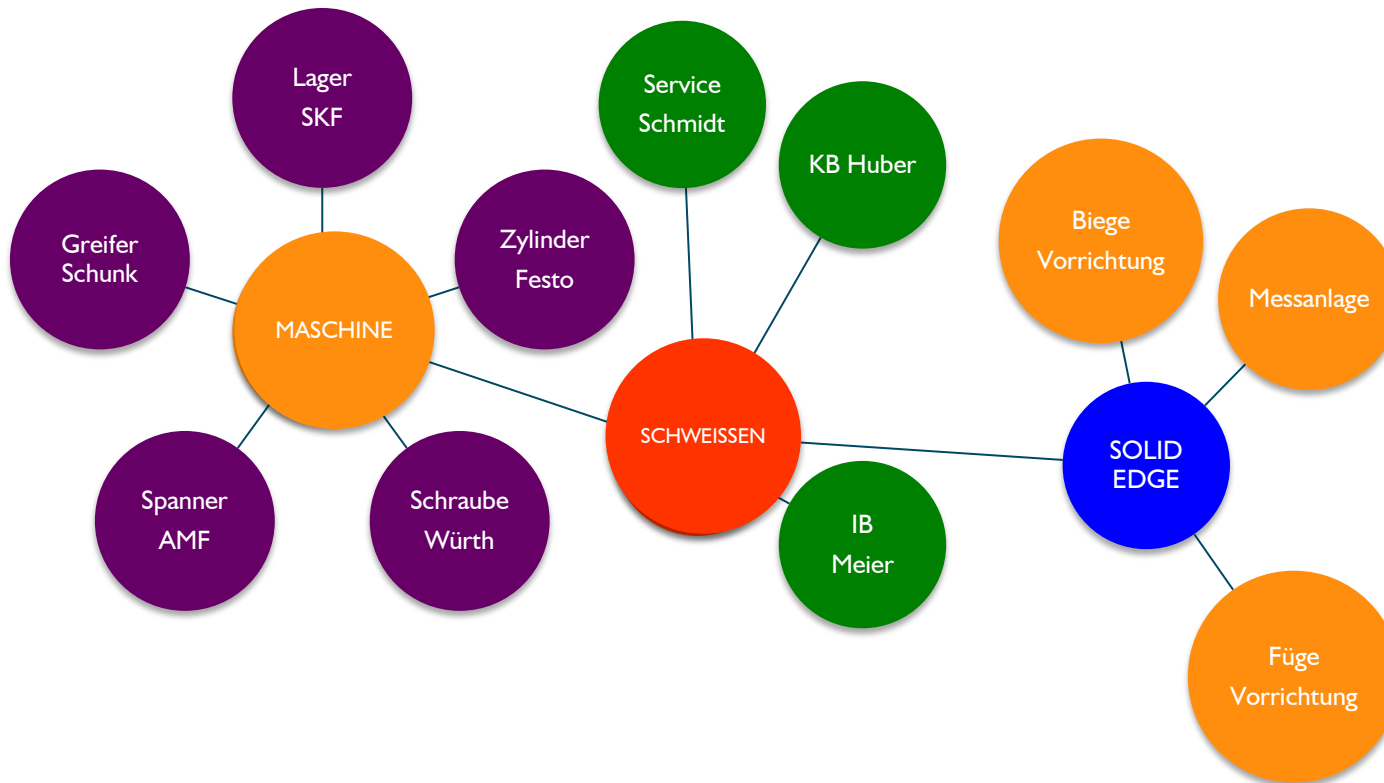



Use cases

Each group benefits!

CAD PRODUCER

Benefits since he can show that his CAD is suitable for this kind of design.

PRESS

Journalists get a research data base for new reports and publications

ENGINEERS

Benefit from **ENGINEERING COMPETITIONS** and can win generous prizes

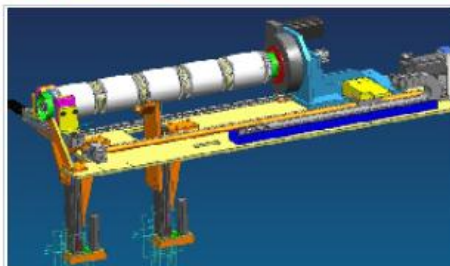
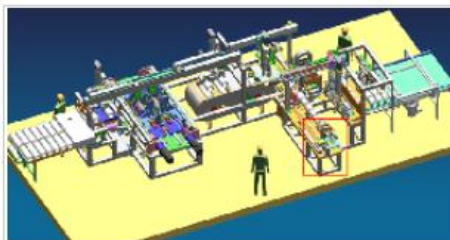

ENGINEER SERVICE PROVIDERS

Good advertisement – an advertising slogan or company logo can be attached to every use case

MANUFACTURERS

Get feedback to optimize their parts or get new ideas for innovations



Use cases

Intelligent queries:

Know how to use **components** in the right way!

Are there use cases showing how this **component** can be installed/used?

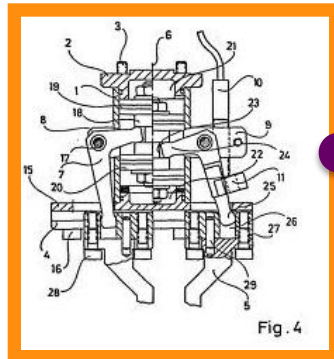
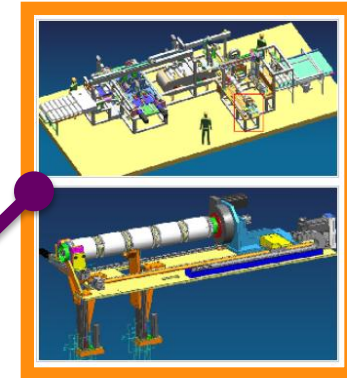



Use cases

Intelligent queries: Choose the right **manufacturer**
Which **manufacturer** and **component** do I need for this kind
of machine?

eCATALOG
SOLUTIONS

THE ELECTRONIC
PRODUCT CATALOG

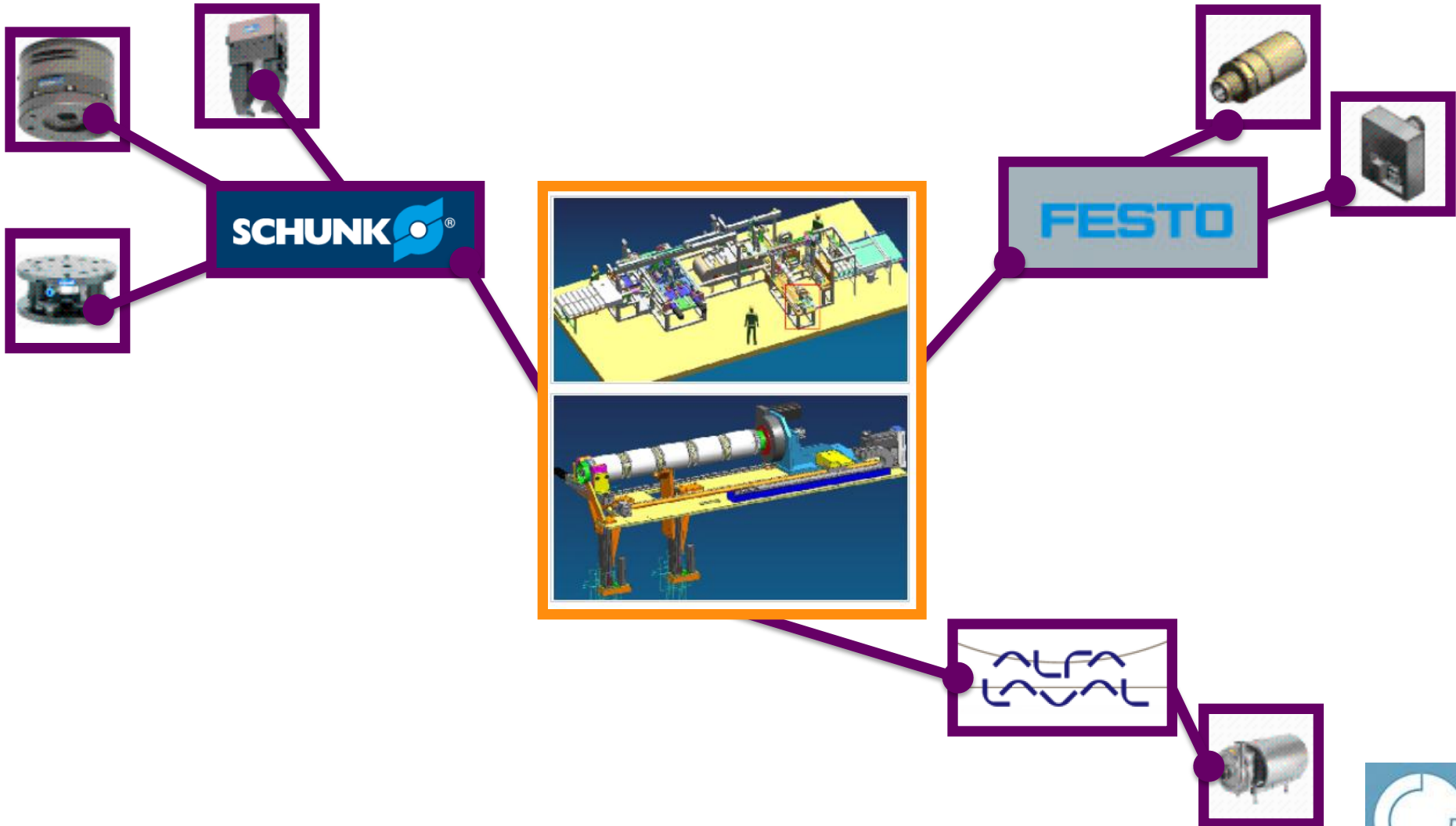



Use cases

Intelligent queries: **Look for a good service provider**

Who is the expert (**Engineering service provider**) for this kind of machine? Who has experience?

eCATALOG
SOLUTIONS

THE ELECTRONIC
PRODUCT CATALOG

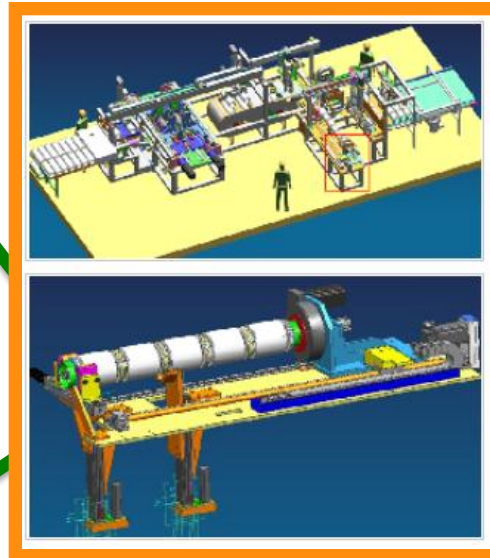

Use cases

Intelligent queries: **Supporting the design process**

Are there examples of devices that support the welding process?

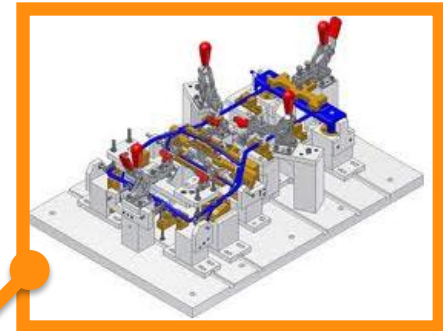



Use cases

Intelligente queries: **Look for a service provider?**
Who is the expert for this CAD system?

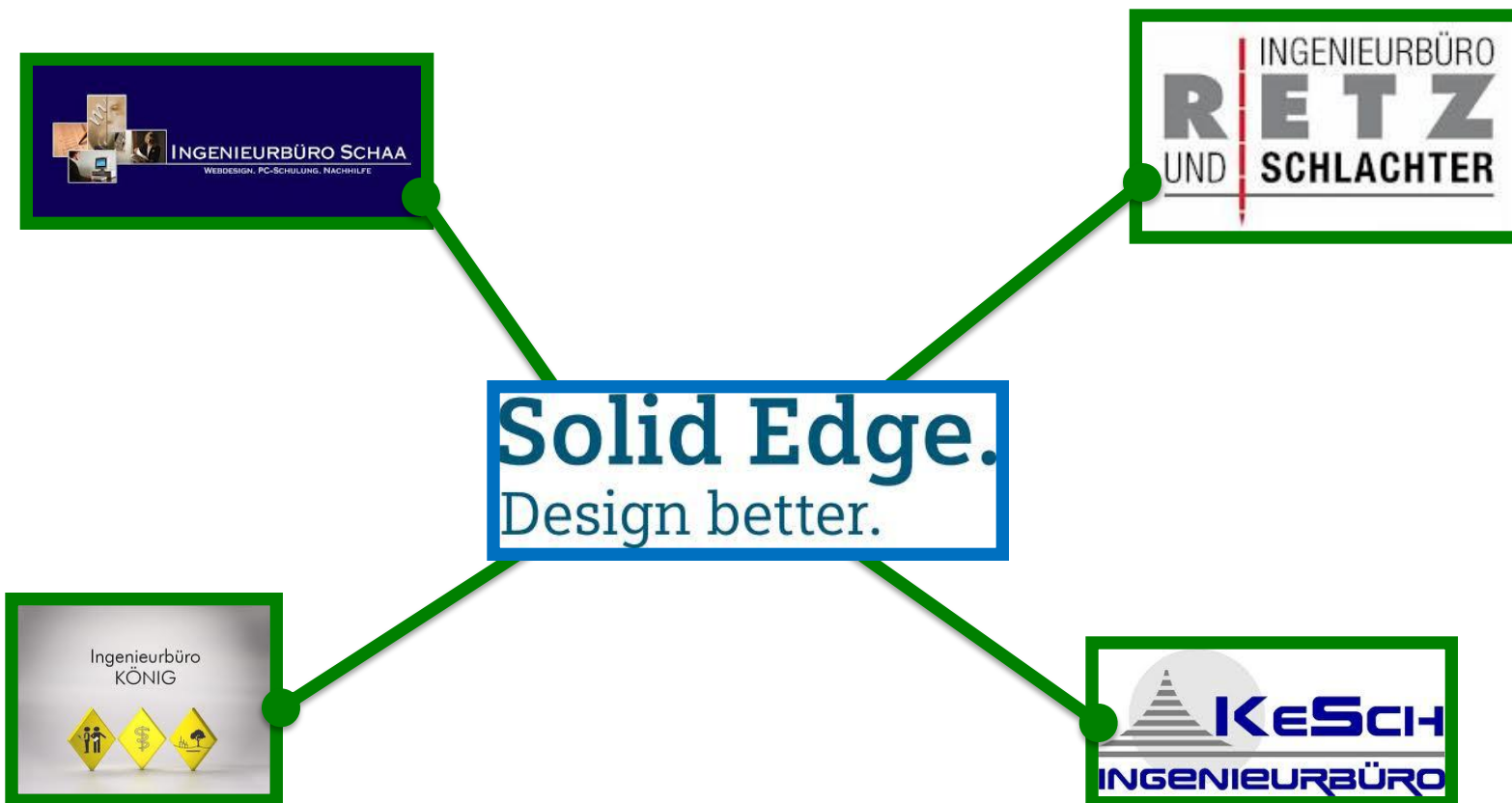



Use cases

Intelligent queries: **Supporting the CAD selection**

What kind of machines are frequently developed with this CAD system?

eCATALOG SOLUTIONS

THE ELECTRONIC PRODUCT CATALOG

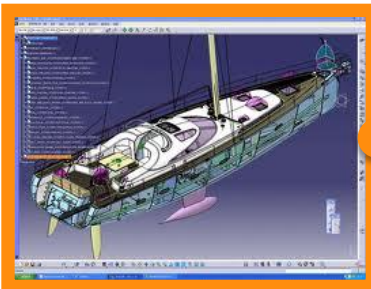



Use cases

Intelligent queries: **Supporting the CAD selection**

Which CAD system is normally used for these machines?

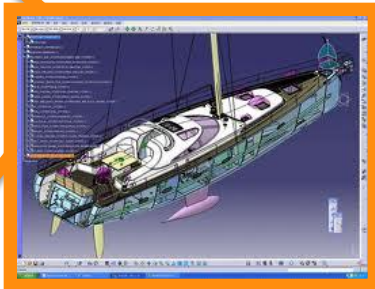



Amazon approach

Quickly find the right locking ring for the selected bearing.

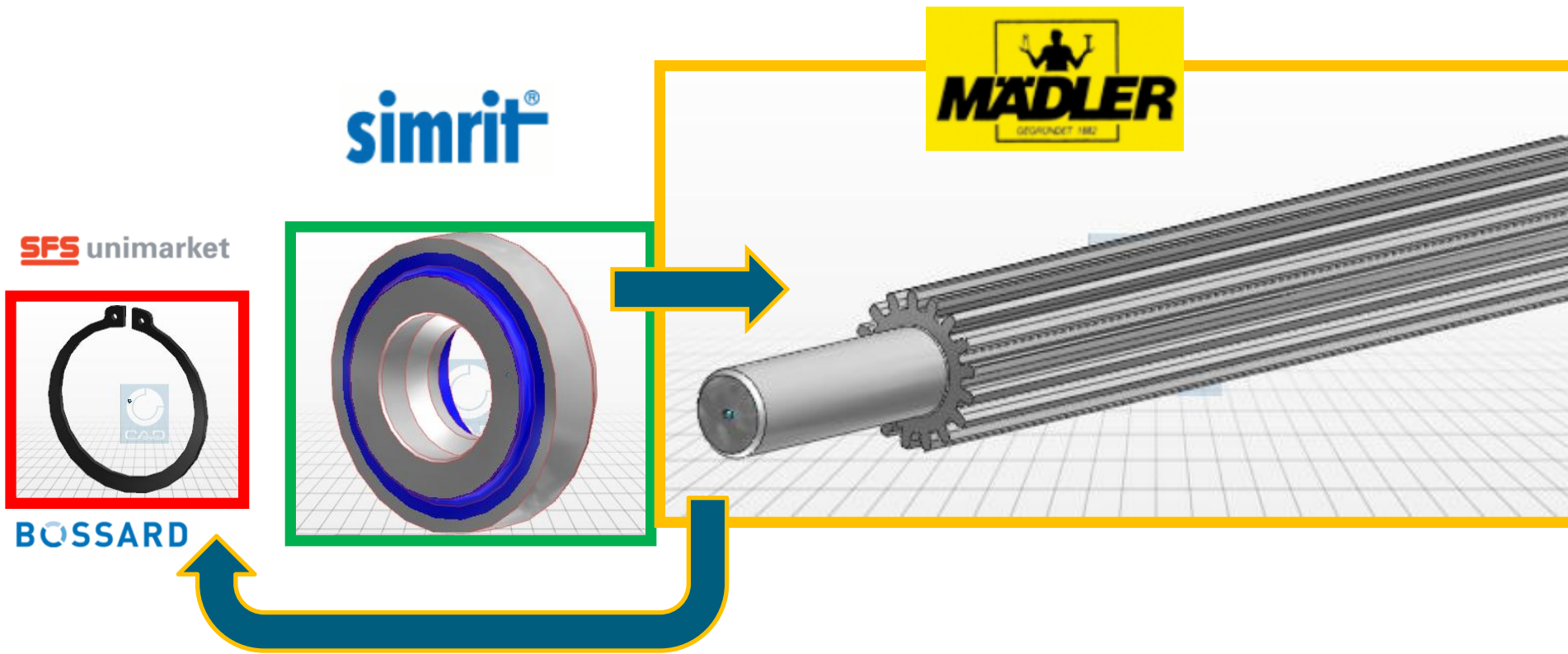

We motivate manufacturers

Tender awards for motivated **engineers** with the
ENGINEERING CHALLENGE PLATFORM

eCATALOG
SOLUTIONS

**THE ELECTRONIC
PRODUCT CATALOG**

1x Samsung Galaxy Note 10.1

sponsored by
GANTER



EINSATZ VON NORMELEMENTEN AUS DEM HAUSE GANTER IN KONSTRUKTIVEN LÖSUNGEN!

Der Teilnehmer mit dem interessantesten
Anwendungsbeispiel für Ganter gewinnt ein Galaxy
Note 10.1

Veranstalter: Otto Ganter GmbH & Co. KG

Teilnehmer: B2B PARTcommunity User aus
deutschsprachigem Raum

Aufgabe: Schicken Sie uns Ihre Anwendungen mit
Ganter-Produkten

Laufzeit: bis 16.11.2012

Prämie: 1x Samsung Galaxy Note 10.1

[Mehr erfahren »](#)



Ideas for eChallenges and Awards

eCATALOG
SOLUTIONS

THE ELECTRONIC
PRODUCT CATALOG





Thank you
very much
for your attention

Questions ?

Feedback ?

Dipl. Ing. (FH) JÜRGEN HEIMBACH, CEO

Phone.: +49 (0)821 2 58 58 0 - 0

Email: J.Heimbach@cadenas.de

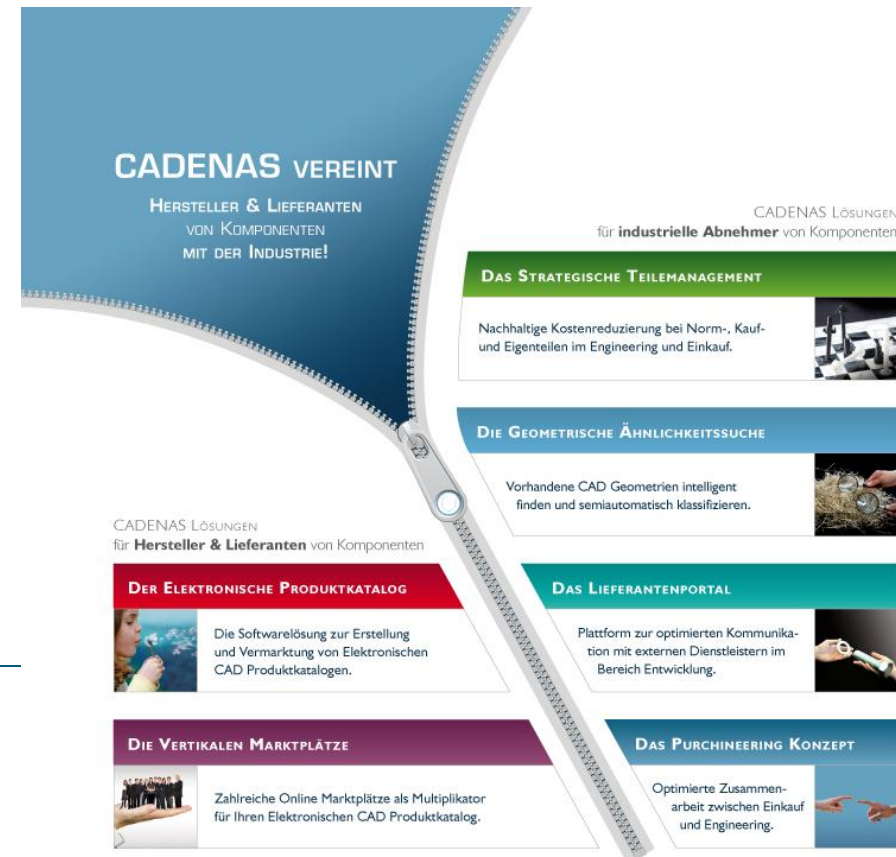



Property, Copyright and Disclaimer

CADENAS

SETTING STANDARDS

This document and all information it contains are the property of the CADENAS AG. Delivery of this document or display of its content does not create a right to the intellectual property. This document may not be copied or made available to third parties without the written consent of the CADENAS AG. This document and its content may only be used for the purposes they were intended for.

All statements made in this document do not constitute an offer. They were made bona fide on the basis of specified assumptions. If the reason for the statements are not indicated, the CADENAS AG will gladly explain the statements to you.

